

M E R L I N

U S A

B O T T O M B R A C K E T<sup>®</sup>

G R E A S E G U A R D M A N U A L

F O R A L L 1 9 9 1 M O D E L S A N D L A T E R

2 0 0 1

1

COPYRIGHT 2001 MERLIN METALWORKS<sup>®</sup>



# MERLIN BOTTOM BRACKET® GREASE GUARD MANUAL

## TABLE OF CONTENTS

- 3)...BRACKET ILLUSTRATION
- 4)...SPINDLE TOOL KIT CONTENTS
- 5)...BEARING INSTALLATION KIT CONTENTS
  - 6)...SPINDLE REMOVAL
  - 7)...SPINDLE INSTALLATION
  - 8)...BEARING REMOVAL
  - 9)...BEARING INSTALLATION
- 12)...BEARING INSTALLATION TABLE

## TOOLS NEEDED

- 1)...CIRCLIP PLIERS (I.D. TYPE)
- 2)...TWO 5/8-INCH OPEN-END WRENCHES
- 3)...3/8-INCH (APPROX.) ALUMINUM DOWEL OR DRIFT
- 4)...TWO 14-MM OPEN-END WRENCHES
- 5)...BENCH VISE



# MERLIN BOTTOM BRACKET® GREASE GUARD MANUAL

## BRACKET ILLUSTRATION

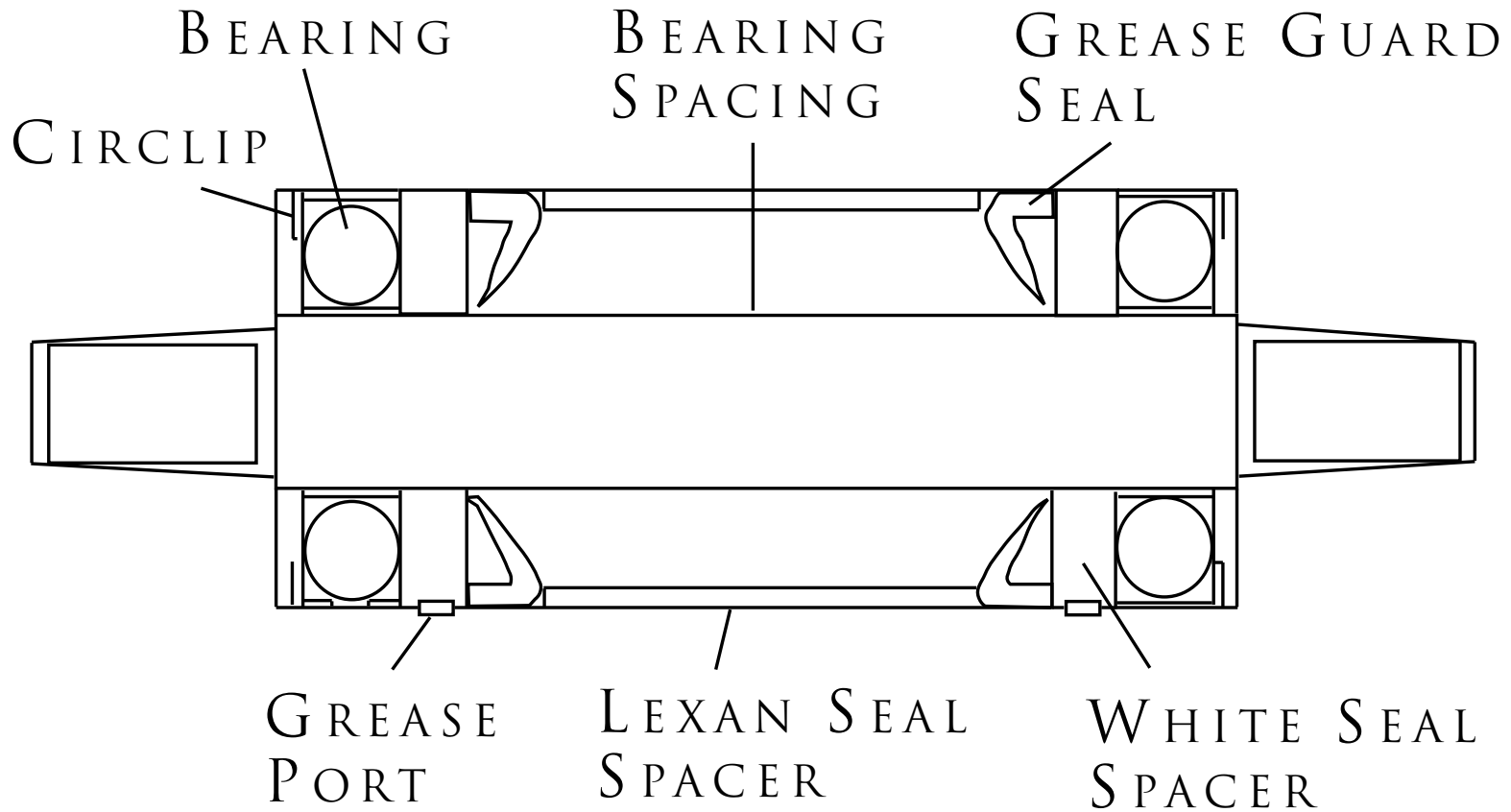



# MERLIN BOTTOM BRACKET® GREASE GUARD MANUAL

## SPINDLE TOOL KIT CONTENTS

REMOVAL TOOL

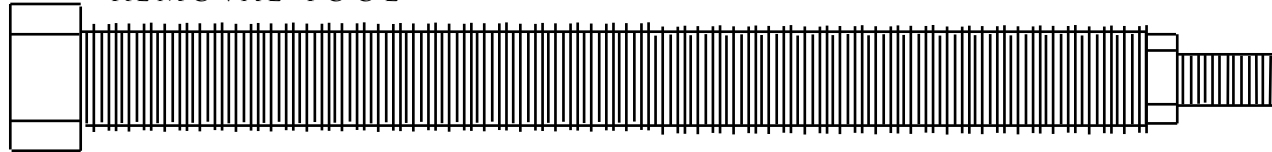

4 3/4-INCH SLEEVE



1 5/16-INCH  
SLEEVE

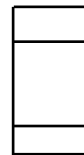

5/8-INCH NUT

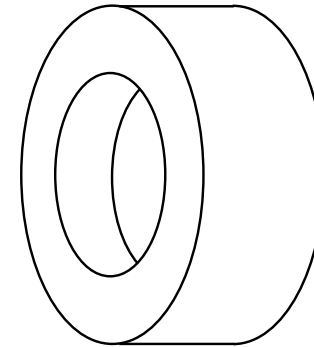

STEPPED STEEL WASHER

- 1 - REMOVAL TOOL WITH 8X1 MM STUD
- 12 - 5/8-INCH NUT
- 1 - STEPPED STEEL WASHER
- 2 - STEEL SLEEVES: 1 5/16 AND 4 3/4 INCHES



# MERLIN BOTTOM BRACKET® GREASE GUARD MANUAL

## BEARING INSTALLATION KIT

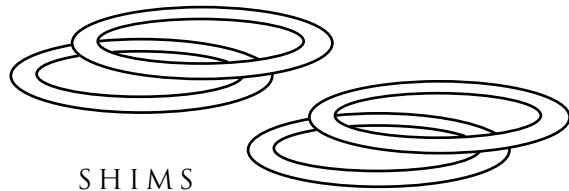

SHIMS

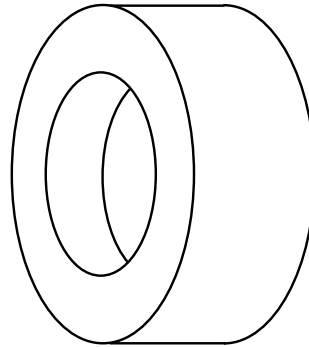

STEEL WASHER

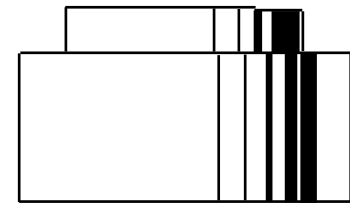

ALUMINUM BLOCK

- 2 - ALUMINUM BLOCKS
- 2 - STEEL WASHERS FOR SPINDLE BOLTS
- 6 - 0.093" SHIMS
- 6 - 0.020" SHIMS



# MERLIN BOTTOM BRACKET® GREASE GUARD MANUAL

## SPINDLE REMOVAL

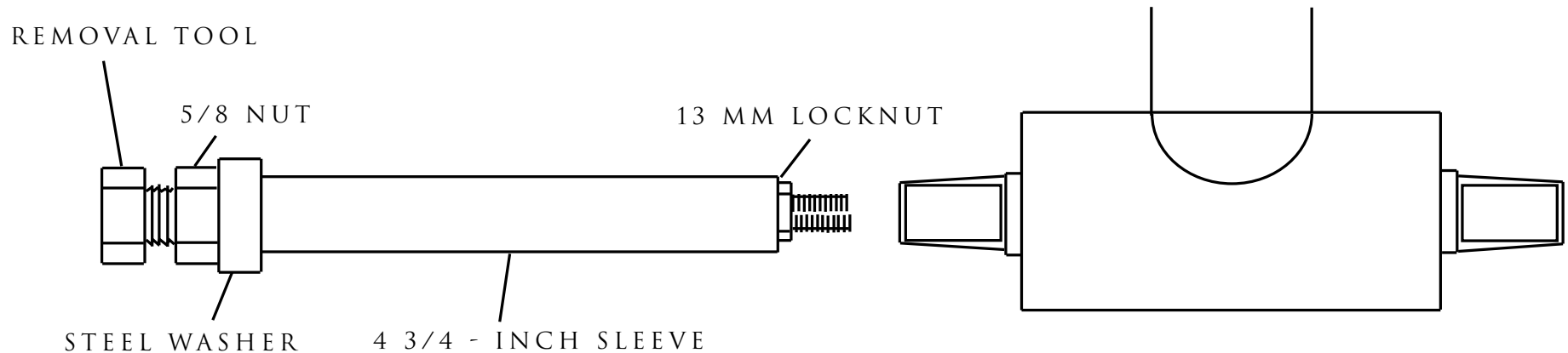

- 1) REMOVE CRANKARM BOLTS, IF PRESENT.
- 2) RUN THE 5/8-INCH NUT TO THE HEAD OF THE REMOVAL TOOL
- 3) PUT THE STEPPED STEEL WASHER ON THE TOOL.
- 4) PUT THE 4 3/4-INCH SLEEVE ON THE TOOL.
- 5) THREAD THE TOOL INTO THE SPINDLE AND TIGHTEN.
- 6) TIGHTEN THE NUT AGAINST THE WASHER AND SLEEVE.
- 7) HOLD THE 5/8-INCH NUT AND TURN THE SPINDLE TOOL COUNTERCLOCKWISE. THE SLEEVE WILL PRESS AGAINST THE BEARING AND EXTRACT THE SPINDLE.



# MERLIN BOTTOM BRACKET® GREASE GUARD MANUAL

## SPINDLE INSTALLATION

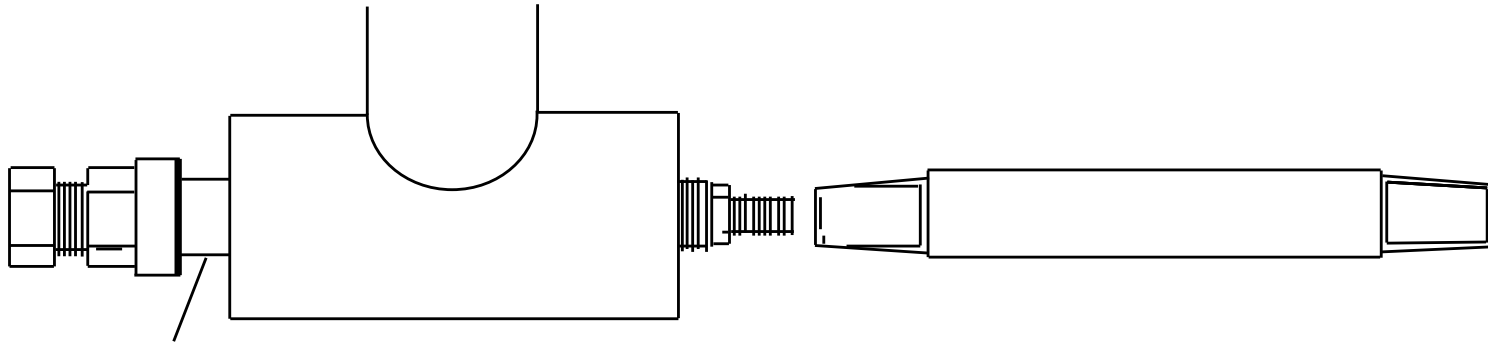

1 5/16 - INCH SLEEVE

- 1) MAKE SURE THE BEARING SPACER INSIDE THE BB SHELL IS NOT COCKED OR DISPLACED.
- 2) RUN THE 5/8-INCH NUT TO THE HEAD OF THE SPINDLE TOOL. PUT THE STEPPED STEEL WASHER ON THE TOOL. PUT THE 1 5/16-INCH SLEEVE ON THE TOOL.
- 3) PUSH THE TOOL THROUGH THE BOTTOM BRACKET, LEAVING BEARINGS AND SPACERS INTACT.
- 4) THREAD THE SPINDLE ONTO THE TOOL AND TIGHTEN. DO NOT LUBRICATE THE SURFACE OF THE SPINDLE.
- 5) TIGHTEN THE BUT AGAINST THE SLEEVE.
- 6) HOLD THE 5/8-INCH NUT AND TURN THE SPINDLE TOOL COUNTERCLOCKWISE. THE SLEEVE WILL PRESS AGAINST THE BEARING AND PULL THE SPINDLE INTO PLACE. ADJUST THE LATERAL POSITION OF THE SPINDLE WITH THE SHORT STEEL SLEEVE.



# MERLIN BOTTOM BRACKET® GREASE GUARD MANUAL

## BEARING REMOVAL

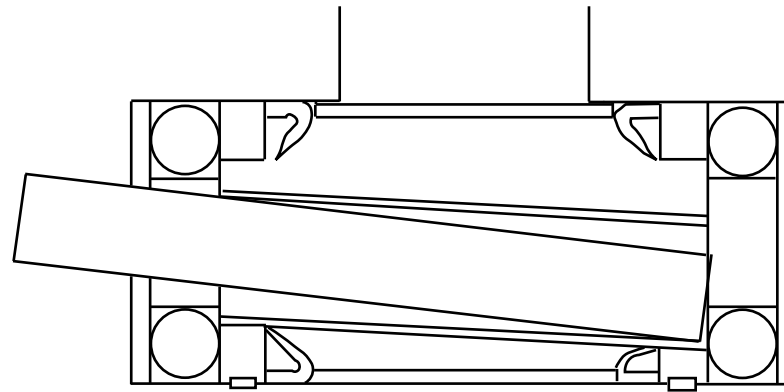

- 1) REMOVE THE SPINDLE.
- 2) REMOVE THE BEARING CIRCLIPS.
- 3) USING A 3/8-INCH DOWEL (APPROXIMATE SIZE), PUSH THE BEARING SPACER DOWN OUT OF THE WAY AND PUNCH OUT THE BEARINGS EVENLY. BE CAREFUL NOT TO DAMAGE THE BEARING SPACER, CLEAR LEXAN SEAL SPACER, OR GREASE PORTS INSIDE THE SHELL.





# MERLIN BOTTOM BRACKET® GREASE GUARD MANUAL

## BEARING INSTALLATION-(A)

PRESS SPACER FLUSH WITH SPINDLE END.

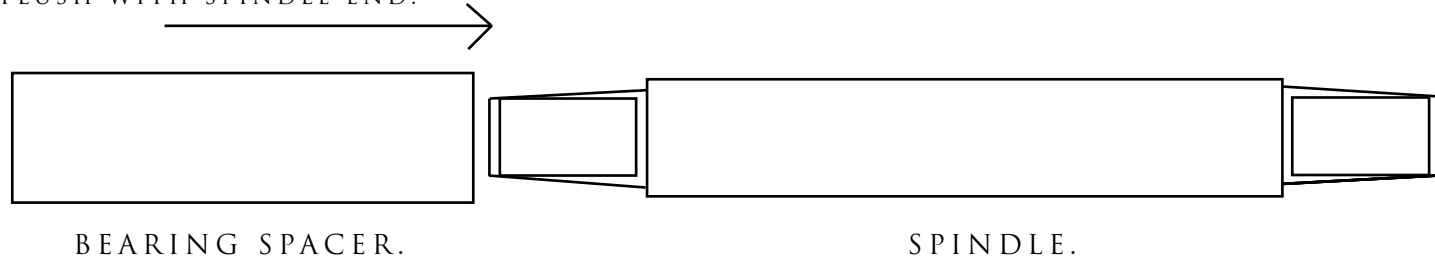

- 1) USING THE ALUMINUM BLOCK, ONE BEARING (OPEN SIDE FACING IN), AND THE APPROPRIATE SHIMS (IF NECESSARY; SEE TABLE), PRESS THE BEARING SPACER AND THE BEARING THE REST OF THE WAY ONTO THE SPINDLE. THIS WILL CENTER THE SPACER.
- 2) PLACE A 3/8-INCH WASHER ONTO THE ALUMINUM BLOCK (AND SHIMS, IF PRESENT) AND INSTALL THE 14-MM SPINDLE BOLT. SNUG THE BOLT BY HAND.
- 3) SLIDE THE SPINDLE INTO THE SHELL FROM THE DRIVE SIDE. BE CAREFUL NOT TO BEND BACK THE LIPS OF THE BLACK GREASE SEALS.
- 4) PUT THE OTHER BEARING ONTO THE SPINDLE, OPEN END FACING IN. PLACE THE ALUMINUM BLOCK ONTO THE BEARING AND PRESS THE BEARING INTO THE SHELL BY HAND TO START IT INTO PLACE. THEN INSTALL SHIMS, IF NECESSARY (SEE TABLE), A 3/8-INCH WASHER, AND THE SPINDLE BOLT.
- 4) USING THE ALUMINUM BLOCK, ONE BEARING (OPEN SIDE FACING IN), AND THE APPROPRIATE SHIMS (IF NECESSARY; SEE TABLE), PRESS THE BEARING SPACER AND THE BEARING THE REST OF THE WAY ONTO THE SPINDLE. THIS WILL CENTER THE SPACER.



# MERLIN BOTTOM BRACKET® GREASE GUARD MANUAL

## BEARING INSTALLATION-(B)

PRESS BEARING & SPACER ONTO SPINDLE. →

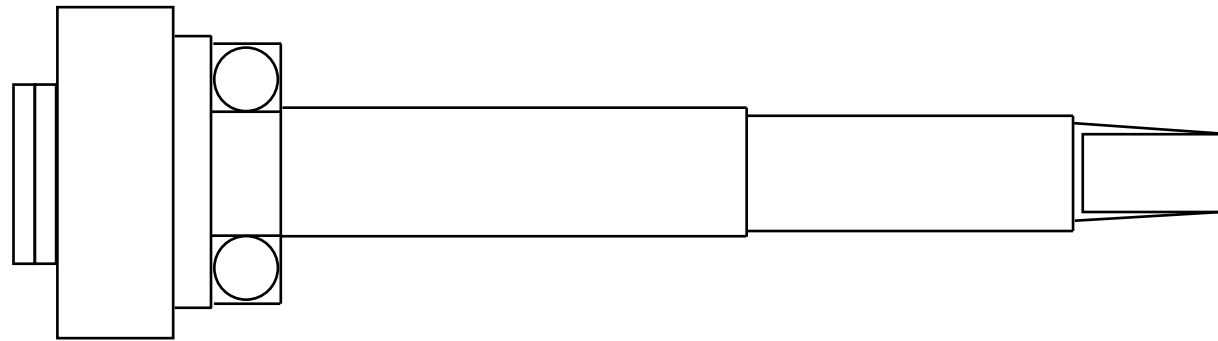

- 1) PLACE A 3/8-INCH WASHER ONTO THE ALUMINUM BLOCK (AND SHIMS, IF PRESENT) AND INSTALL THE 14-MM SPINDLE BOLT. SNUG THE BOLT BY HAND.
- 2) SLIDE THE SPINDLE INTO THE SHELL FROM THE DRIVE SIDE. BE CAREFUL NOT TO BEND BACK THE LIPS OF THE BLACK GREASE SEALS.
- 3) PUT THE OTHER BEARING ONTO THE SPINDLE, OPEN END FACING IN. PLACE THE ALUMINUM BLOCK ONTO THE BEARING AND PRESS THE BEARING INTO THE SHELL BY HAND TO START IT INTO PLACE. THEN INSTALL SHIMS, IF NECESSARY (SEE TABLE), A 3/8-INCH WASHER, AND THE SPINDLE BOLT.



# MERLIN BOTTOM BRACKET® GREASE GUARD MANUAL

## BEARING INSTALLATION-(C)

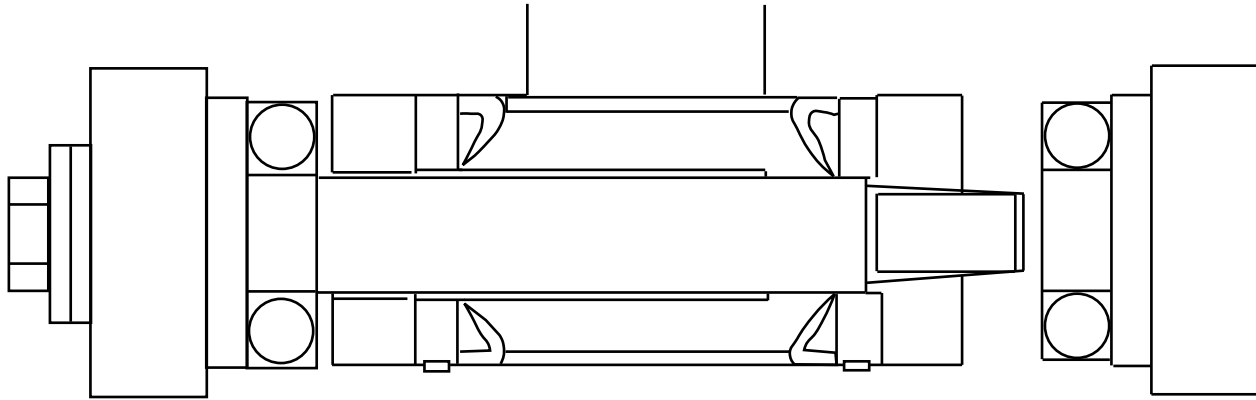

- 1) WITH TWO 14-MM WRIENCHES, HOLD THE DRIVE-SIDE SPINDLE BOLT AND TIGHTEN THE LEFT SPINDLE BOLT TO PRESS THE BEARINGS INTO PLACE.
- 2) REMOVE THE BOLTS, SHIMS, WASHERS, AND BLOCKS.
- 3) REPLACE THE CIRCLIPS. GREASE THE BEARINGS.



# MERLIN BOTTOM BRACKET® GREASE GUARD MANUAL

## BEARING INSTALLATION TABLE

### SPINDLE LENGTH BLOCKS & SHIMS

113 MM	Aluminum Block Only
119 MM	Aluminum Block Only 1x 0.093" 1x 0.020"
122.5 MM	Aluminum Block Only 2 x 0.093"
125 MM	Aluminum Block Only 2 x 0.093" 3 x 0.020"
113 MM	Aluminum Block Only 3 x 0.093" 3 x 0.020"